

SCHEMATIC DIAGRAM (DSP)

Point ① (Pin 1 of IC501)
V : 2V/div, H : 50 nsec/div
DC, 1 : 1 probe

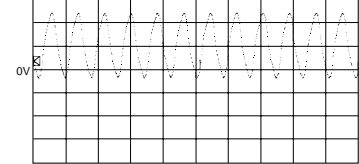

Point ② (Pin 56 of IC503)
V : 2V/div, H : 50 nsec/div
DC, 1 : 1 probe

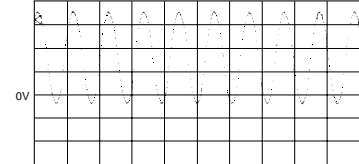

IC505 : P002SE25M2P
+2.5V Regulator

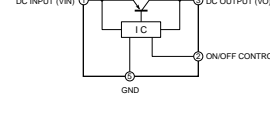

IC512, 515-519, 525-527 :
µPC4570G2
IC509 : NJM2904M-T1
Dual OP Amp

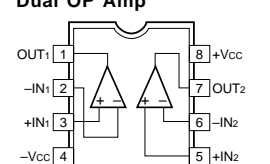

IC507, 513 : TC74HC04F
Quad 2 Input NAND

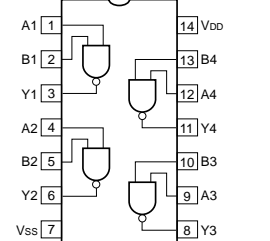

IC510, 511 : TC74HC04F-TP1
Hex Inverters

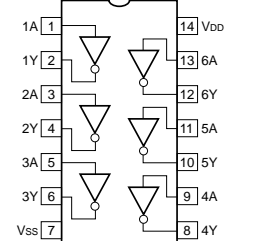

IC508 : TC74HC08F
Quad 2 Input AND

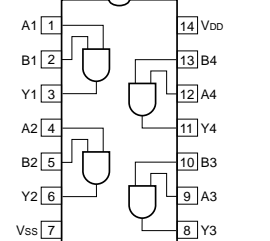

IC520, 523 : DF1704E
24 bit Digital Filter

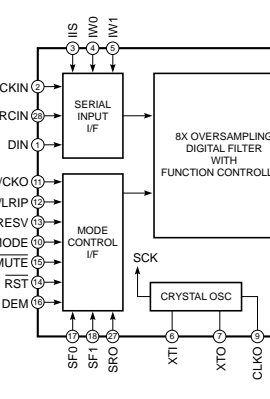

IC521, 522, 524 : PCM1704F
24 bit D/A Converter

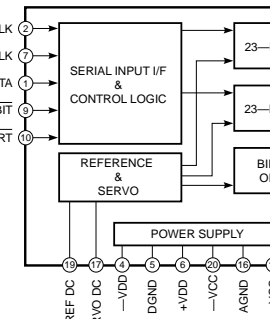

IC514 : AK4527VQ
96kHz 24 bit 6ch CODEC

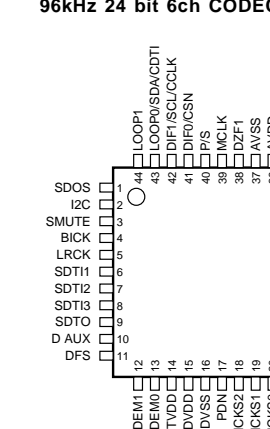

IC502 : MSM514260C-60JS
262,144-word x 16 bit Dynamic RAM

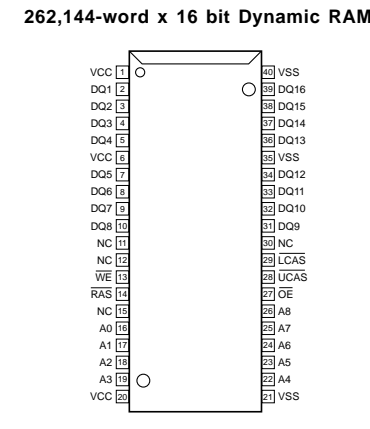

IC504 : CY62256L-70SNCT
32K X 8 bits Static RAM

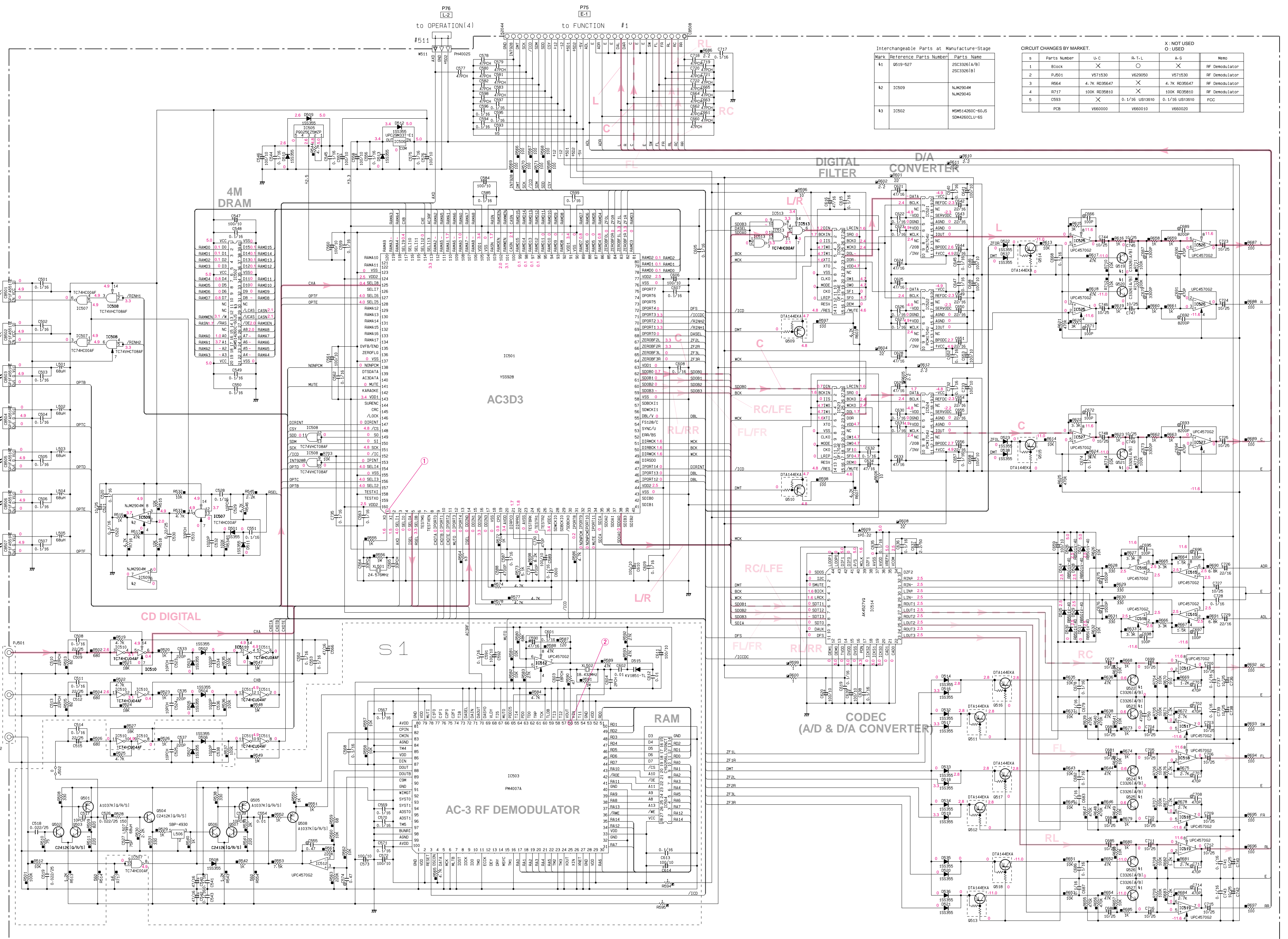
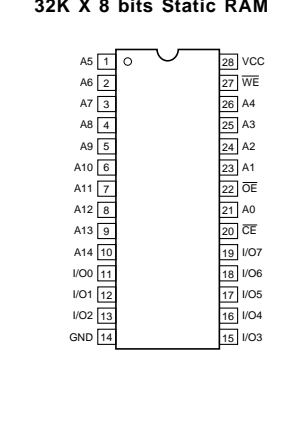

Interchangeable Parts at Manufacture-Stage

Mark	Reference Parts Number	Parts Name
K1	9519-927	2SC3326(A/B) 2SC3326(B)
K2	IC509	NJM2904M NJM2904
K3	IC502	MSM514260C-60JS SDM4260CJU-65

CIRCUIT CHANGES BY MARKET

s	Parts Number	U-C	R-T-L	A-G	Memo
1	B501	X	○	X	RF Demodulator
2	F501	X	○	X	RF Demodulator
3	R564	4.7K R035647	X	4.7K R035647	RF Demodulator
4	R717	100K R035810	X	100K R035810	RF Demodulator
5	C593	X	0.1/16 UB13810	0.1/16 UB13810	FCC
	PCB	V660000	V660010		

X: NOT USED
○: USED

- Conditions
- INPUT: DVD auto
 - PROGRAM: PRO LOGIC DSP
 - All voltage are measured with a 10MΩ/V DC electric volt meter.
 - Components having special characteristics are marked with a triangle symbol and must be replaced with parts having specifications equal to those originally installed.
 - Schematic diagram is subject to change without notice.

SCHEMATIC DIAGRAM (FUNCTION)

Point ③ (Pin 20 of IC26)
V: 2V/div, H: 50 nsec/div
DC, 1: 1 probe

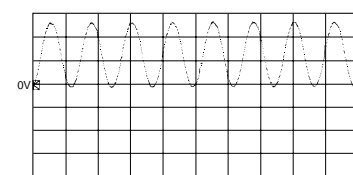

Point ④-A (+MB: Emitter of Q506)
Point ④-B (RES: Collector of Q507)
V: 5V/div (+MB), V: 1V/div (RES)
DC, 1: 1 probe, H: 1 sec/div

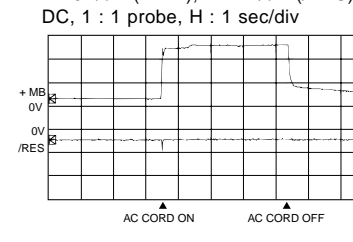

IC503, 512: LC78211 Analog Function Switch

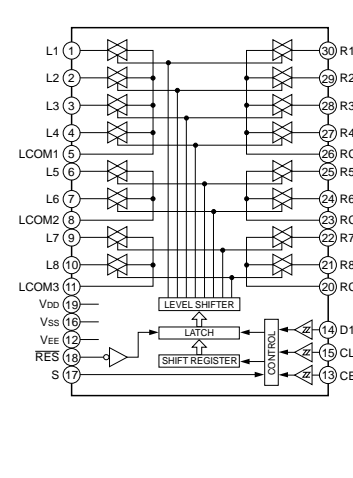

IC502, 504: LC78212 Analog Function Switch

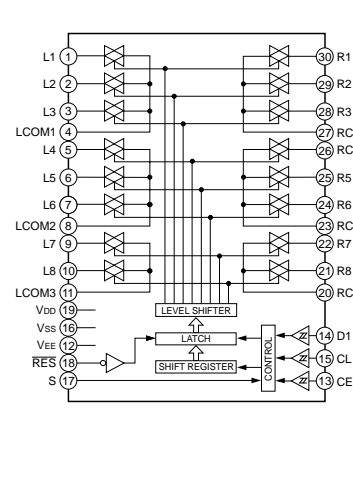

IC505, 522: LC78213 Analog Function Switch

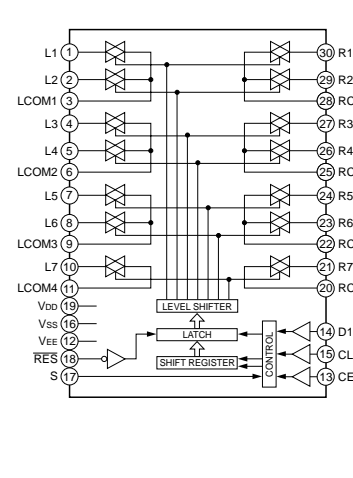

IC501: NJM2068MD-T1

IC506-509, 511, 513-515, 521, 523-525: μPC4570G2 Dual OP-Amp

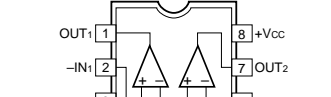

IC510: LC7536-Y Electric Controlled Volume

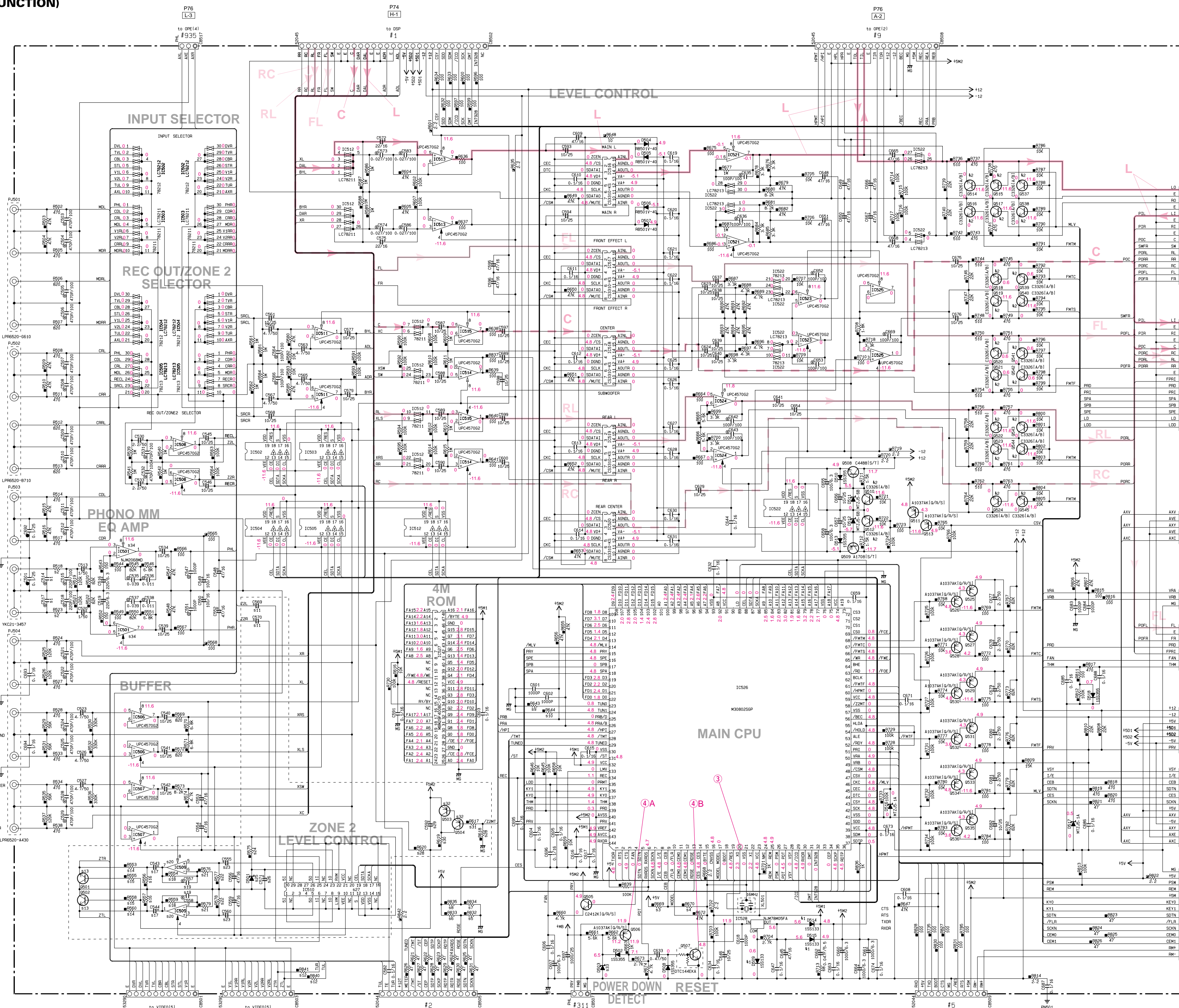
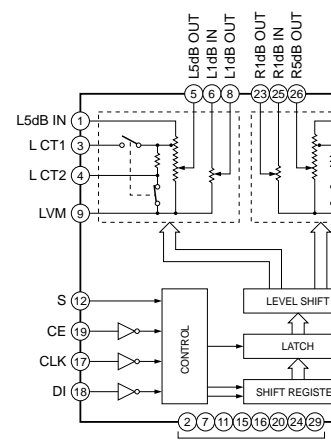

CIRCUIT CHANGES BY MARKET. X: NOT USED

Table with 5 columns: Circuit No., U-C, R-T, A, and RES. It lists various components and their market availability for different regions.

Table with 5 columns: Circuit No., U-C, R-T, A, and RES. It lists various components and their market availability for different regions.

Other Parts
JY501-504, 505, 508-510 1477550
JY506-509 1477550
JY502-503-507 1477570
PN501-502 3759200
ST501 8807136

Table with 3 columns: Mark, Reference Parts Number, and Parts Name. It lists interchangeable parts at the manufacturer's stage.

IC527: MBM29F400C-70 4M Bit Flash Memory

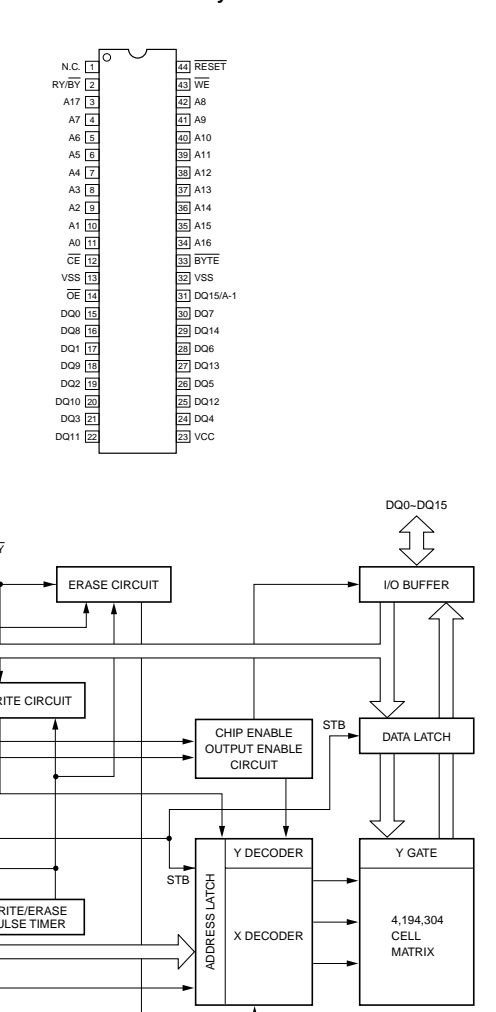

- Conditions
- INPUT: DVD auto
- PROGRAM: PRO LOGIC DSP

- All voltage are measured with a 10MΩ/V DC electric volt meter.
- Components having special characteristics are marked with a triangle and must be replaced with parts having specifications equal to those originally installed.
- Schematic diagram is subject to change without notice.

IC516-520: CS3310-KSR Stereo Digital Volume Control

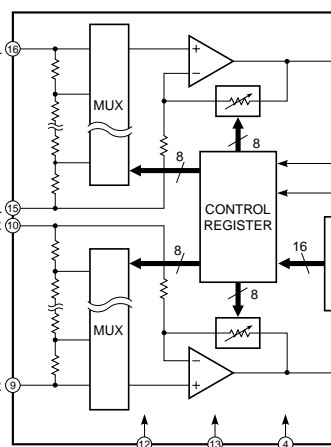

■ SCHEMATIC DIAGRAM (OPERATION)

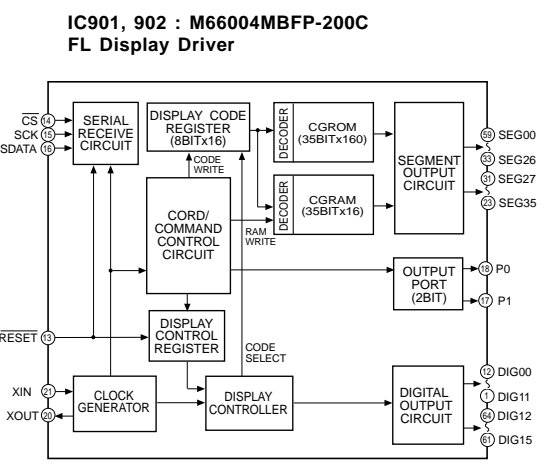
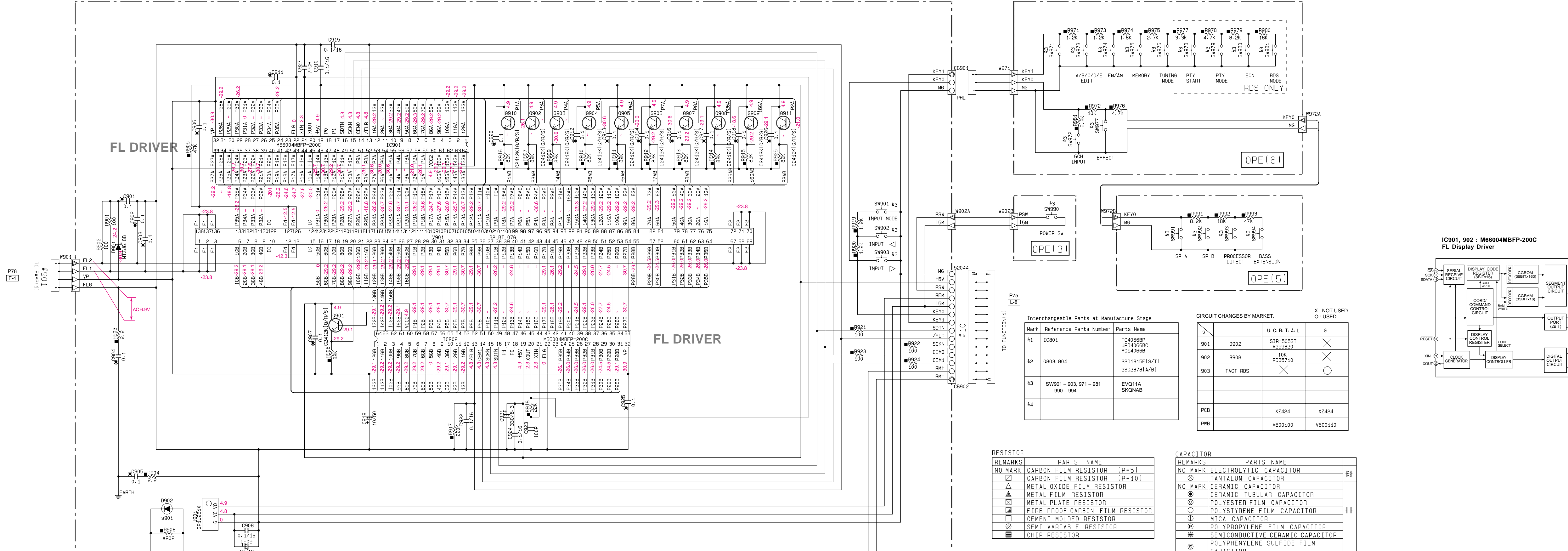
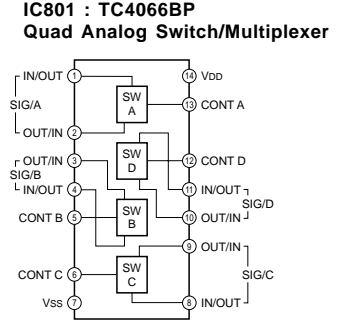
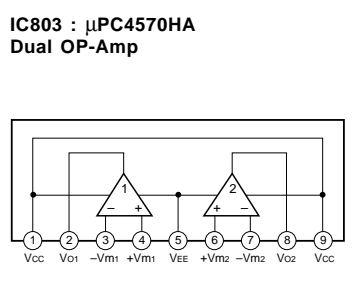
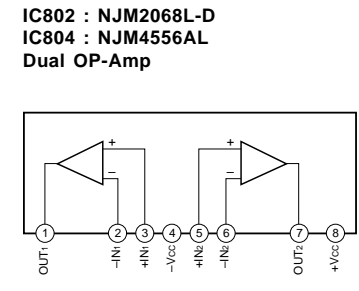
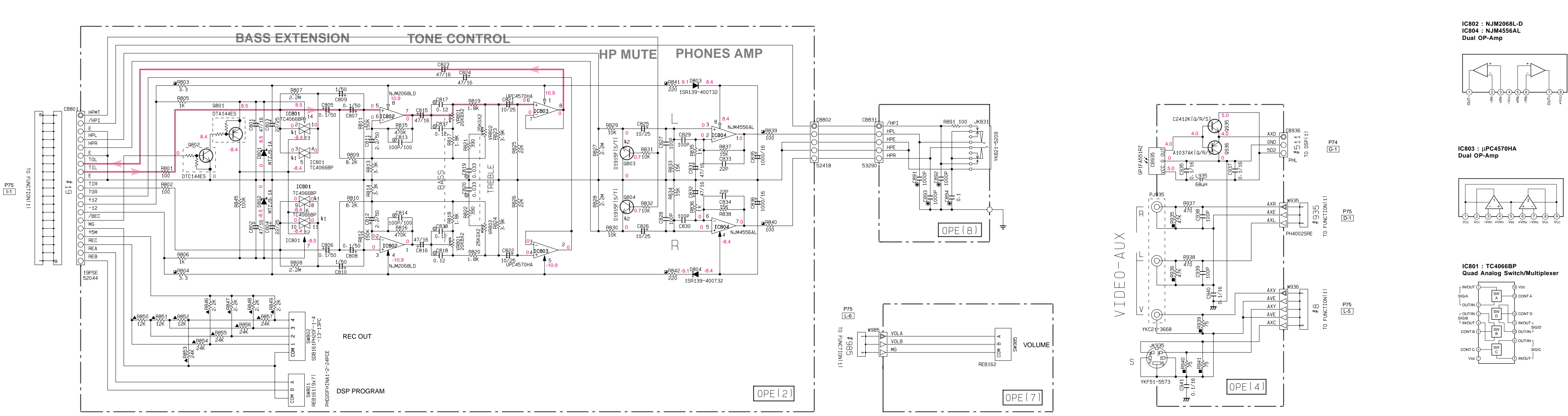

Interchangeable Parts at Manufacture-Stage

Mark	Reference Parts Number	Parts Name
K1	IC801	TC4066BP UP04666BC MC14066B
K2	Q803-Q804	2SD1915F(S/T1) 2SC2878(A/B)
K3	SW901-903, 971-981 990-994	EVO11A SKONAB
K4		

CIRCUIT CHANGES BY MARKET.

s	U-C-R-T-A-L	G	
901	D902	SUR-505ST V250B02	X
902	R908	10K RD36710	X
903	TACT RDS		○
PCB		XZ424	XZ424
PWB		V600100	V600110

RESISTOR

REMARKS	PARTS NAME
NO MARK	CARBON FILM RESISTOR [D=5]
□	CARBON FILM RESISTOR [D=10]
△	METAL OXIDE FILM RESISTOR
▲	METAL FILM RESISTOR
■	FIRE-PROOF CARBON FILM RESISTOR
□	CEMENT MOLDED RESISTOR
⊠	SEMI-VARIABLE RESISTOR
⊞	CHIP RESISTOR

CAPACITOR

REMARKS	PARTS NAME
NO MARK	ELECTROLYTIC CAPACITOR
⊗	TANTALUM CAPACITOR
NO MARK	CERAMIC CAPACITOR
●	CERAMIC TUBULAR CAPACITOR
⊙	POLYESTER FILM CAPACITOR
○	POLYSTYRENE FILM CAPACITOR
⊖	MICA CAPACITOR
⊕	POLYPROPYLENE FILM CAPACITOR
⊗	SEMICONDUCTIVE CERAMIC CAPACITOR
⊙	POLYPHENYLENE SULFIDE FILM CAPACITOR

NOTICE (mode1)
 (J)..... JAPANESE
 (U)..... U.S.A
 (C)..... CANADIAN
 (R)..... GENERAL
 (A)..... AUSTRALIAN
 (B)..... BRITISH
 (G)..... EUROPEAN
 (L)..... CHINA
 (T)..... SINGAPORE

- Conditions
- INPUT: DVD auto
 - PROGRAM: PRO LOGIC DSP
 - All voltage are measured with a 10MΩ/V DC electric volt meter.
 - Components having special characteristics are marked Δ. and must be replaced with parts having specifications equal to those originally installed.
 - Schematic diagram is subject to change without notice.

■ SCHEMATIC DIAGRAM (MAIN)

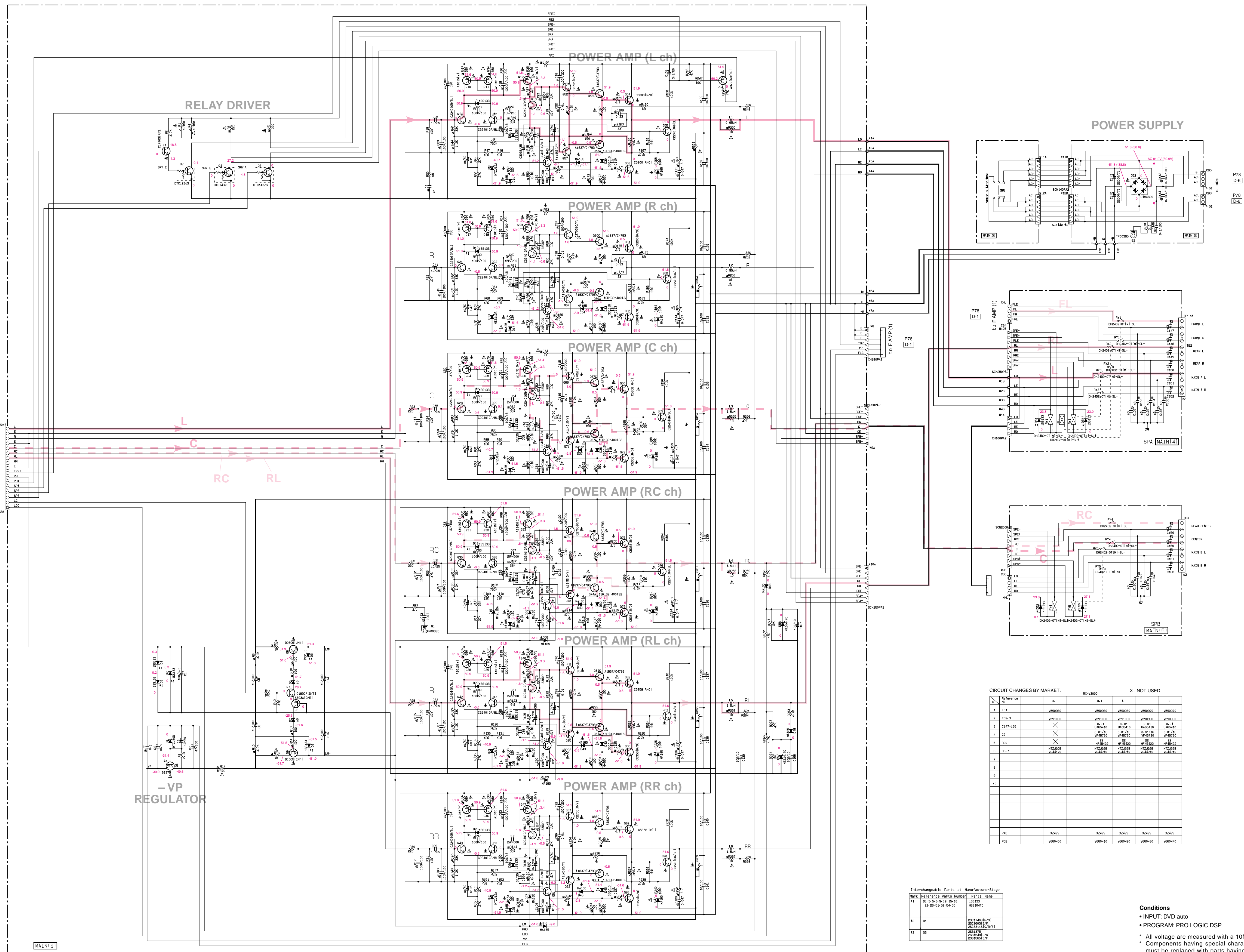

P78
D-6
P78
D-6

CIRCUIT CHANGES BY MARKET. X: NOT USED

Reference No.	U-C	RX-V3000	S-T	A	L	S
1	TE1	V990980	V990980	V990970	V990970	V990970
2	TE2-3	V991000	V991000	V990990	V990990	V990990
3	C147-196	X	0.01	0.01	0.01	0.01
4	C9	X	0.01/16	0.01/16	0.01/16	0.01/16
5	R20	X	1/4W	1/4W	1/4W	1/4W
6	DS-7	WT2-0208 V64417B	WT2-0208 V64417B	WT2-0208 V64417B	WT2-0208 V64417B	WT2-0208 V64417B
7						
8						
9						
10						
P80	XZ429	XZ429	XZ429	XZ429	XZ429	XZ429
PCB	V650400	V650410	V650420	V650430	V650440	V650450

Interchangeable Parts at Manufacture-Stage

Part No.	Reference Part No.	Part Name
K1	20-26-51-50-54-55	100134 R651047D
K2	01	20C140216/P1 20C140217/P1 20C140218/P1
K3	03	20R1376 20R14016/P1 20R14017/P1

- Conditions
- INPUT: DVD auto
 - PROGRAM: PRO LOGIC DSP
 - All voltage are measured with a 10M Ω /V DC electric volt meter.
 - Components having special characteristics are marked Δ and must be replaced with parts having specifications equal to those originally installed.
 - Schematic diagram is subject to change without notice.

SCHEMATIC DIAGRAM (F AMP)

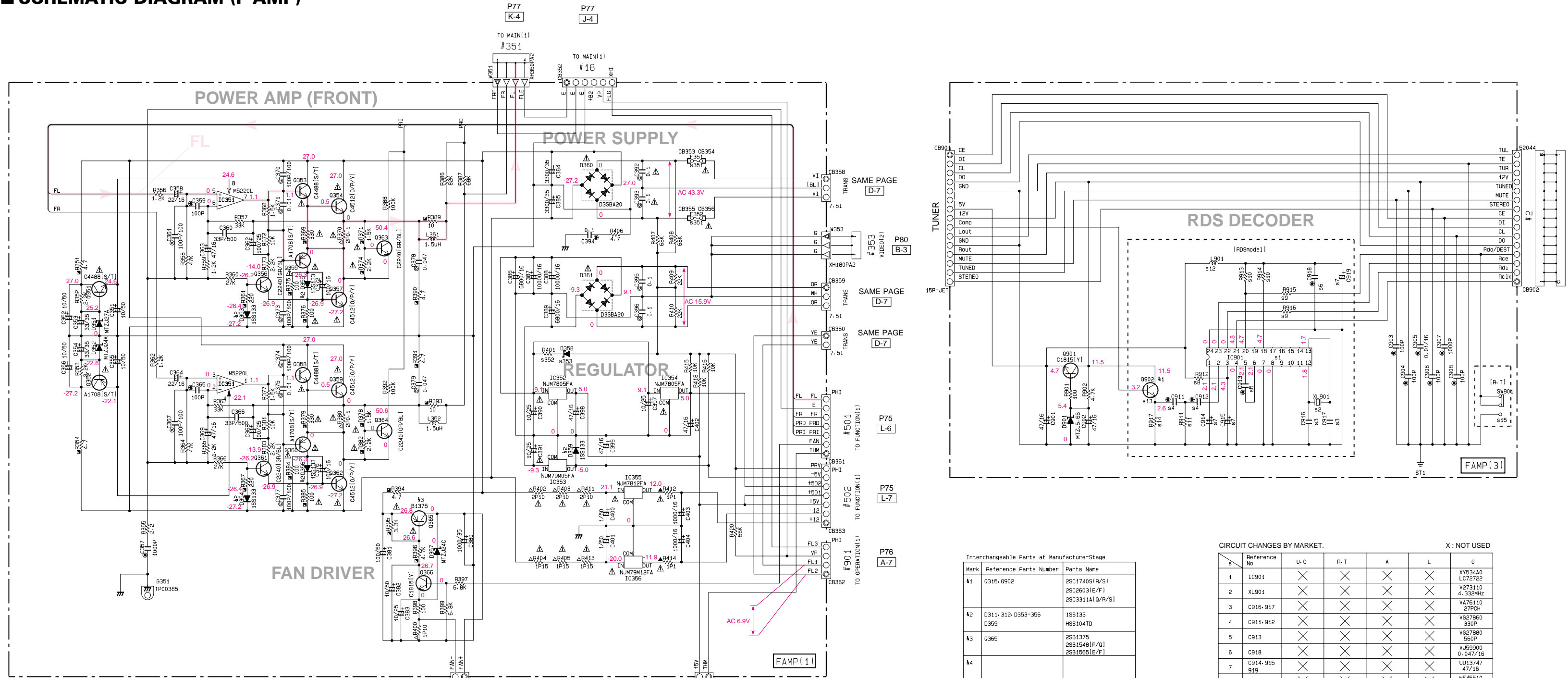

Interchangeable Parts at Manufacture-Stage

Mark	Reference Parts Number	Parts Name
K1	0315-0902	2SC1740S(R/S) 2SC2603(E/F) 2SC3311(A/G/R/S)
K2	0311-312-0363-356 0369	1SS133 H5S104TD
K3	0365	2SB1375 2SB1548(P/G) 2SB1965(E/F)
K4		
K5		

CIRCUIT CHANGES BY MARKET

Mark	Reference No	U-C	R-T	A	L	G
1	IC901	X			X	YV53440 LC72722
2	XL901	X	X	X	X	V273140 4-330MHz
3	C916-947	X	X	X	X	VA76110 27PCH
4	C911-912	X	X	X	X	V627860 330P
5	C913	X	X	X	X	V627860 560P
6	C918	X	X	X	X	VJ59900 0.047/16
7	C914-915 919	X	X	X	X	UJ13747 47/16
8	R912	X	X	X	X	HF45510 10K
9	R915-916	X	X	X	X	HF45547 470
10	R913-914	X	X	X	X	HF45710 10K
11	R911	X	X	X	X	HF45722 20K
12	L901	X	X	X	X	V154610 200µH
13	9902	X	X	X	X	IC17402 C1740S(R/S)
14	R917	X	X	X	X	HF45633 3.3K
15	SW901	X	X	VF54120	X	

X: NOT USED

IC351 : M5220L Dual OP-Amp

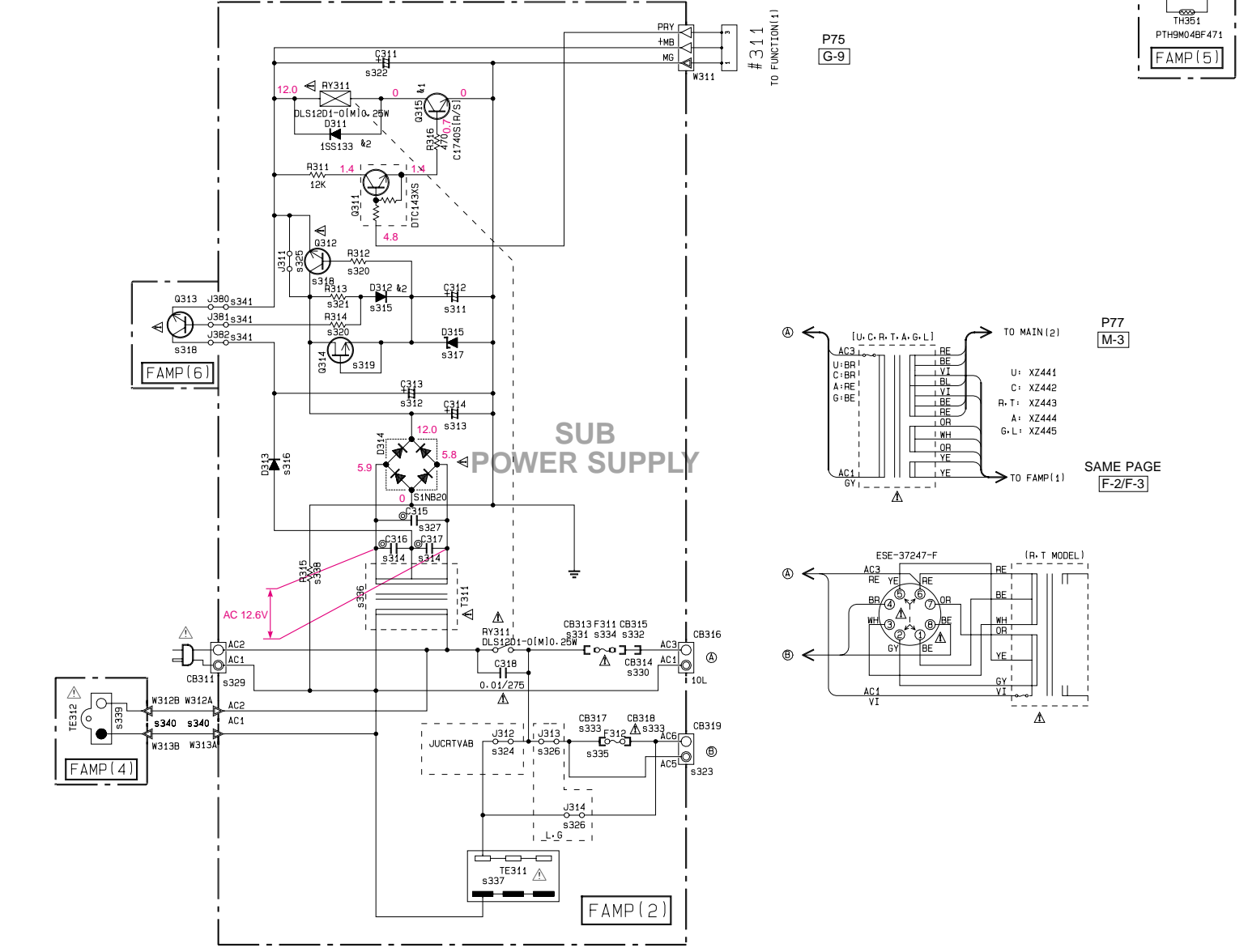
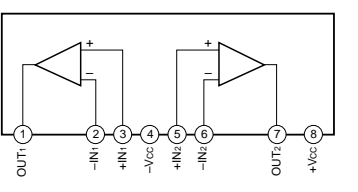

CIRCUIT CHANGES BY MARKET

Reference No	U-C	R-T	A	L	G
311	C312	X	UJ14710 10/25	X	X
312	C313	X	UJ16710 10/50	X	X
313	C314	X	UJ19747 47/250	X	X
314	C316-317	X	0.01 V171670	X	X
315	D312	X	TP0466 1SS133	X	X
316	D313	X	VJ26410 SBL39-40013Z	X	X
317	D315	X	VJ43990 MT215B	X	X
318	D312-313	X	VF0180 D23961(J/K)	X	X
319	D314	X	IE10262 K3461(V)	X	X
320	R312-314	X	HF45510 100	X	X
321	R313	X	HF45710 10K	X	X
322	C311	X	UJ14710 10/25	UJ14710 10/25	UJ14710 10/25
323	CB319	X	LA0244 10K	X	X
324	J912	O	O	O	X
325	J911	O	X	O	O
326	J913-314	X	X	X	O
327	C315	O	0.01 V171670	0.01 V171670	0.01 V171670
328					
329	CB311	X	V687990 V687990	X	X
330	CB314	X	V599610 V599610	X	X
331	CB313	X	V599610 VP20650	VP20650	VP20650
332	CB315	X	VP20650	VP20650	VP20650
333	CB317-318	X	VP20650	VP20650	VP20650
334	F311	X	K800139 10A250V	K800078 T5AL250	K800078 T5AL250
335	F312	X	K800078 T5AL250V	VF4290 T2-5A/250V	VF4290 T2-5A/250V
336	F311	X	X2228 X2229	X2231	X2231
337	TE311	X	VY11880 SP-7631-212	VY15100 SP-7731-210	VY11900 SP-7631-212
338	R315	X	K200511 1/2P2-2M	X	X
339	TE312	X	V656120 M1908-C	V656120 M1908-C	V656120 M1908-C
340	*312-313	X	V656950	X	V656950
341	J380-382	X	O	X	X
342					
351	F351-352	X	5A 125V K800364	5A 250V K800324	5A 250V K800324
352	R401	X	1K HF45510	X	X
353	D358	X	MT215B V6440B	X	X
901	RDS MODEL	X	X	X	O

X: NOT USED
O: USED

REMARKS

REMARKS	PARTS NAME
NO MARK	ELECTROLYTIC CAPACITOR
NO MARK	TANTALUM CAPACITOR
NO MARK	CERAMIC CAPACITOR
●	CERAMIC TUBULAR CAPACITOR
○	POLYESTER FILM CAPACITOR
○	POLYSTYRENE FILM CAPACITOR
○	MICA CAPACITOR
○	POLYPROPYLENE FILM CAPACITOR
●	SEMICONDUCTIVE CERAMIC CAPACITOR
○	POLYPHENYLENE SULFIDE FILM CAPACITOR

REMARKS

REMARKS	PARTS NAME
NO MARK	CARBON FILM RESISTOR (P=5)
□	CARBON FILM RESISTOR (P=10)
△	METAL OXIDE FILM RESISTOR
△	METAL FILM RESISTOR
△	METAL PLATE RESISTOR
△	FINE PROOF CARBON FILM RESISTOR
□	CEMENT MOLDED RESISTOR
○	SEMI VARIABLE RESISTOR
■	CHIP RESISTOR

NOTICE (model)

(J)..... JAPANESE
(U)..... U.S.A
(C)..... CANADIAN
(R)..... GENERAL
(A)..... AUSTRALIAN
(B)..... BRITISH
(G)..... EUROPEAN
(T)..... CHINA
(L)..... SINGAPORE

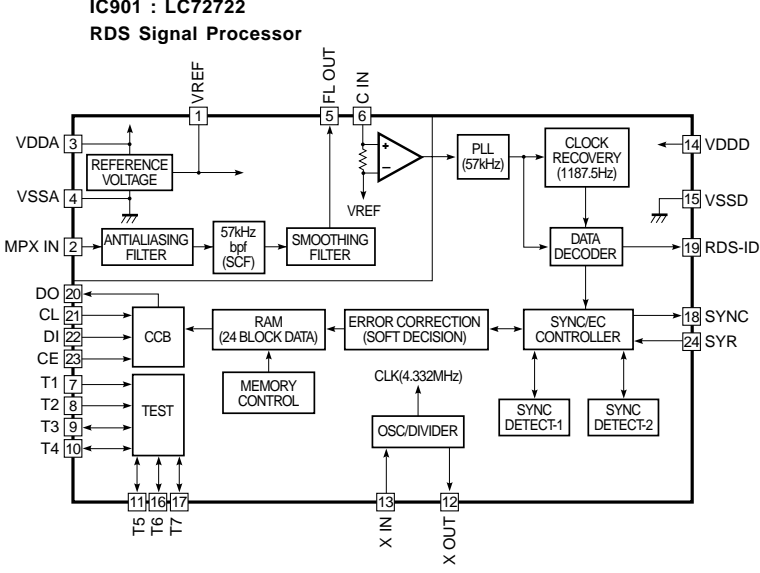

Conditions

- INPUT: DVD auto
- PROGRAM: PRO LOGIC DSP

* All voltage are measured with a 10MΩ/DC electric volt meter.
* Components having special characteristics are marked Δ and must be replaced with parts having specifications equal to those originally installed.
* Schematic diagram is subject to change without notice.

SCHEMATIC DIAGRAM (VIDEO 1/2)

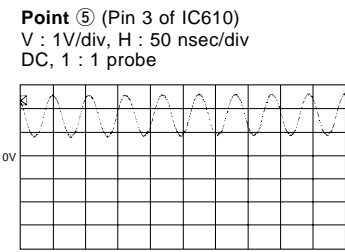

C	B	A
H	Z1	Y1
L	Z0	X0

Y1	Y0	Z1	Z0	INH	VEE	VSS
X4	X3	X2	X1	X0	A	B
VDD	V	U	T	S	R	C

Xn[pin]	C	B	A	INPUT	REC OUT
X0 [13]	L	L	L	SAT	SAT
X1 [14]	L	H	H	DVD/LD	DVD/LD
X2 [15]	L	H	L	D-TV	D-TV
X3 [12]	L	H	H	IHWBIT1	IHWBIT1
X4 [11]	H	L	L	VCR1	VCR1
X5 [6]	H	L	H	VCR2/DVR	VCR2/DVR
X6 [2]	H	H	H	CABLE	CABLE
X7 [4]	H	H	H	V-AUX	V-AUX

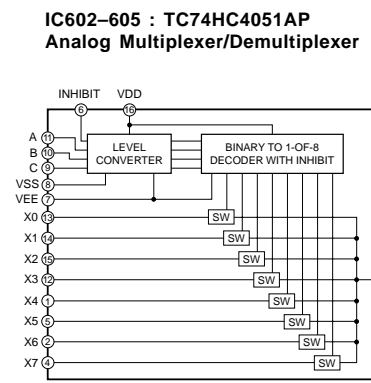
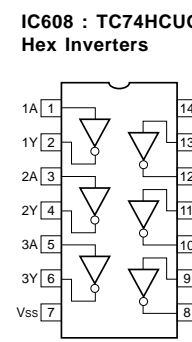
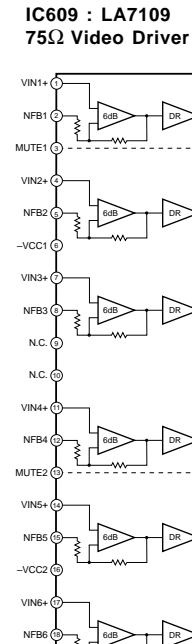
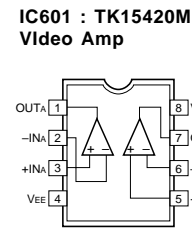
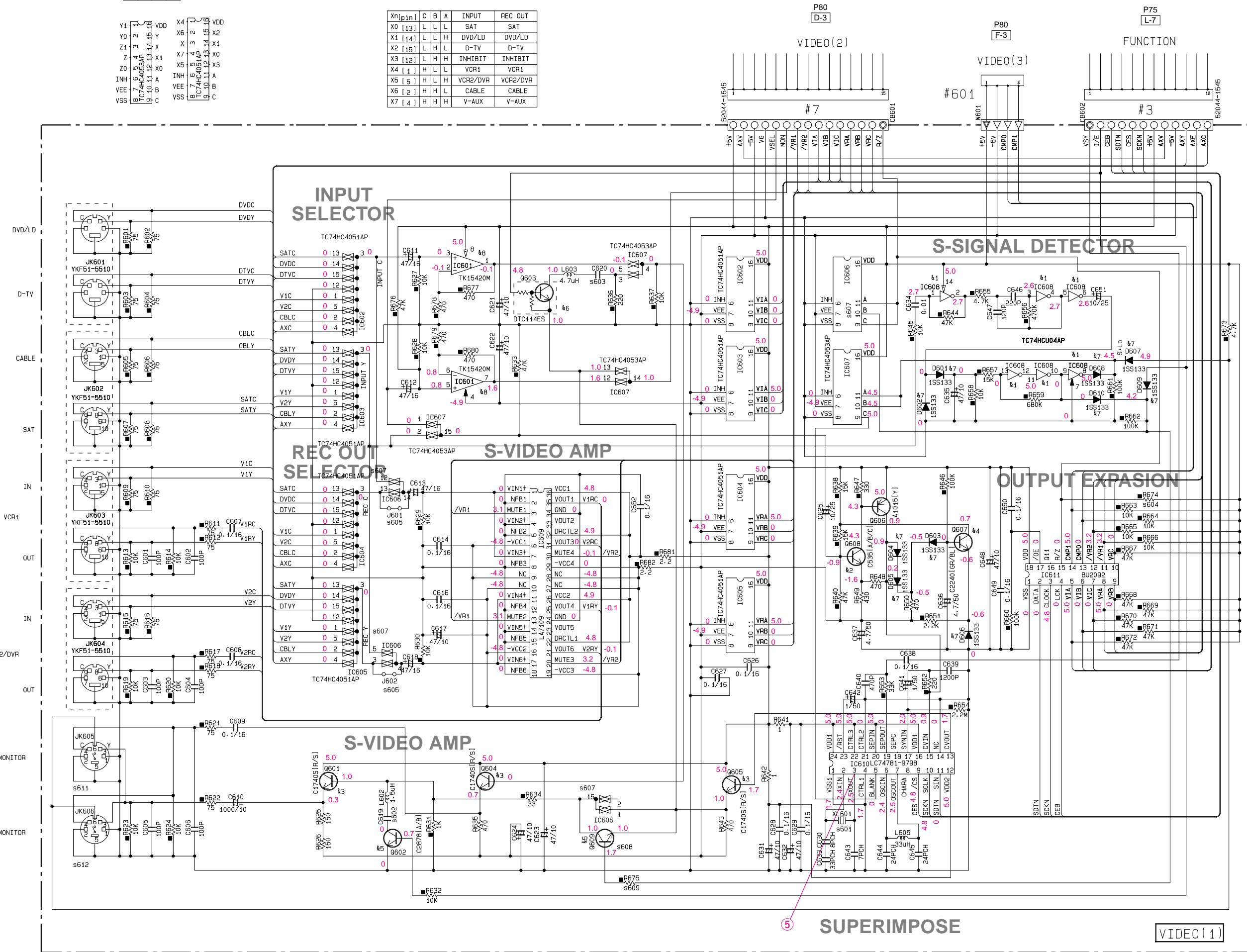

INPUT STATES	ON CHANNEL (S)
0 0 0 0	0
0 0 0 1	1
0 0 1 0	2
0 0 1 1	3
0 1 0 0	4
0 1 0 1	5
0 1 1 0	6
0 1 1 1	7
1 X X X	NONE

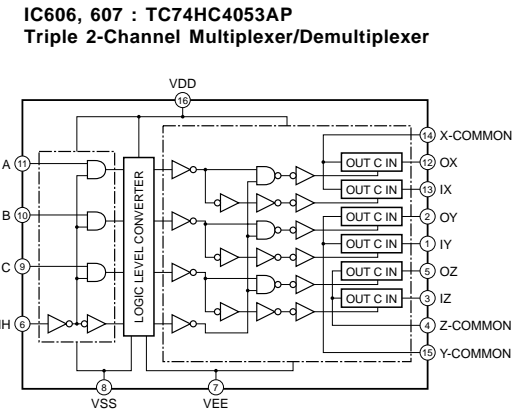

CONTROL INPUTS	ON CHANNEL
INHIBIT (Pin 9)	0X (Pin 10), 0Y (Pin 11), 0Z (Pin 12)
C (Pin 10)	1X (Pin 13), 1Y (Pin 14), 1Z (Pin 15)
B (Pin 11)	2X (Pin 16), 2Y (Pin 17), 2Z (Pin 18)
A (Pin 12)	3X (Pin 19), 3Y (Pin 20), 3Z (Pin 21)
NOTE	

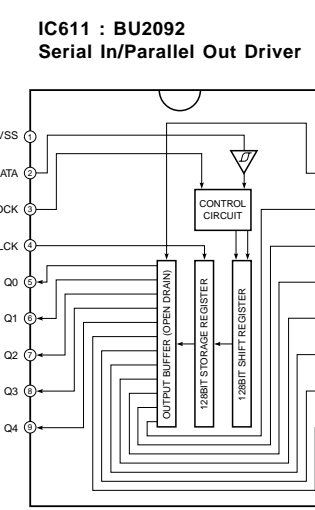

Interchangeable Parts at Manufacture-Stage

Mark	Reference Parts Number	Parts Name
k1	IC608	IC74HC04AP SN74HC04N MC74HC04N
k2	6068	25C5351A/B/C1 25C18091N/P1
k3	6061-604-605-701	25C17403[R/S] 25C2603[E/A] 25C3314[A/R/S]
k4	6067	25C2240[GR/BL] 25C2909[S/T1]
k5	6062-609	25C2878[A/B] 25D1919F[S/T1]
k6	6063	DT114ES UN4211 DT114ESA
k7	D601-602-603-604-605-606-607-608-609-610-951	15S133 HSS104TD
k8	IC601	TK15420M AD6058AR
k9		
k10		
k11		
k12		

CIRCUIT CHANGES BY MARKET. X : NOT USED

s	Parts Number	U-C-R-T	A+L	G
601	XL601	14.31818MHz V934999	17.734475MHz V934999	17.734475MHz V934999
602	C619	1500P US06315	820P US06282	820P US06282
603	C620	390P US06329	270P US06327	270P US06327
604	R674	47K RD35747	47K RD35747	X
605	J601-602	X	X	RD35000
606				
607	IC606	TC74HC4053AP IR40530	TC74HC4053AP IR40530	X
608	6099	X	X	C28781A/B IC28782
609	R675	X	X	10K RD35710
610				
611	JK605	X	X	YKFB1-5507 V956040
612	JK606	YKFB1-5507 V956040	YKFB1-5507 V956040	X
701				
702	R713	75 RD35475	75 RD35475	X
703	R714	10K RD35710	10K RD35710	X
704	C704	100P US06210	100P US06210	X
705	C711	4710 UR62747	4710 UR62747	X
706	IC704	TC74HC4053AP IR40530	TC74HC4053AP IR40530	X
707	J703	X	X	RD35000
708	R579, 682	470 HF45547	470 HF45547	X
709	C567, 568	470P/100 LP65247	470P/100 LP65247	X
710	PJ705	YK21-3111 VJ69590	YK21-3111 VJ69590	YK21-3165 YH11010
711	J701	X	X	YM60000
712	J702	YM60000	YM60000	X
751				
752				
753				
754				
755				
551				
952	PJ554	LP96520-9720 V385610	LP96520-9720 V385610	LP96520-9610 V385660
951	JK951-952-953	VJ72680	VJ72680	X
952	D951	15S133 IF00460	15S133 IF00460	X
953	R958	IP100 YP94040	IP100 YP94040	X

RESISTOR

REMARKS	PARTS NAME
NO MARK	CARBON FILM RESISTOR (P=5)
□	CARBON FILM RESISTOR (P=10)
△	METAL OXIDE FILM RESISTOR
▲	METAL FILM RESISTOR
■	METAL PLATE RESISTOR
⊠	FIRE PROOF CARBON FILM RESISTOR
□	CEMENT MOLDED RESISTOR
⊙	SEMI VARIABLE RESISTOR
■	CHIP RESISTOR

CAPACITOR

REMARKS	PARTS NAME
NO MARK	ELECTROLYTIC CAPACITOR
⊗	TANTALUM CAPACITOR
NO MARK	CERAMIC CAPACITOR
●	CERAMIC TUBULAR CAPACITOR
○	POLYESTER FILM CAPACITOR
⊙	POLYSTYRENE FILM CAPACITOR
⊖	MICA CAPACITOR
⊕	POLYPROPYLENE FILM CAPACITOR
⊗	SEMICONDUCTIVE CERAMIC CAPACITOR
⊙	POLYPHENYLENE SULFIDE FILM CAPACITOR

NOTICE (mode1)
 (J)..... JAPANESE
 (U)..... U.S.A
 (C)..... CANADIAN
 (R)..... GENERAL
 (A)..... AUSTRALIAN
 (B)..... BRITISH
 (G)..... EUROPEAN
 (T)..... CHINA
 (L)..... SINGAPORE

- Conditions
- INPUT: DVD auto
 - PROGRAM: PRO LOGIC DSP
 - All voltage are measured with a 10MΩ/V DC electric volt meter.
 - Components having special characteristics are marked △ and must be replaced with parts having specifications equal to those originally installed.
 - Schematic diagram is subject to change without notice.

SCHEMATIC DIAGRAM (VIDEO 2/2)

RESISTOR

REMARKS	PARTS NAME
NO MARK	CARBON FILM RESISTOR (P=5)
□	CARBON FILM RESISTOR (P=10)
△	METAL OXIDE FILM RESISTOR
◇	METAL FILM RESISTOR
■	METAL PLATE RESISTOR
▨	FIRE PROOF CARBON FILM RESISTOR
□	CEMENT MOLDED RESISTOR
◇	SEMI VARIABLE RESISTOR
■	CHIP RESISTOR

CAPACITOR

REMARKS	PARTS NAME
NO MARK	ELECTROLYTIC CAPACITOR
□	TANTALUM CAPACITOR
NO MARK	CERAMIC CAPACITOR
○	CERAMIC TUBULAR CAPACITOR
⊙	POLYESTER FILM CAPACITOR
⊚	POLYSTYRENE FILM CAPACITOR
⊕	MICA CAPACITOR
⊖	POLYPROPYLENE FILM CAPACITOR
⊗	SEMICONDUCTIVE CERAMIC CAPACITOR
⊘	POLYPHENYLENE SULFIDE FILM CAPACITOR

NOTICE (mode1)
 (J)..... JAPANESE
 (U)..... U.S.A
 (C)..... CANADIAN
 (R)..... GENERAL
 (A)..... AUSTRALIAN
 (B)..... BRITISH
 (G)..... EUROPEAN
 (T)..... CHINA
 (L)..... SINGAPORE

Xn[pin]	C	B	A	INPUT	REC OUT
X0 [13]	L	L	L	SAT	SAT
X1 [14]	L	L	H	DVD/LD	DVD/LD
X2 [15]	L	H	L	D-TV	D-TV
X3 [12]	L	H	H	INHIBIT	INHIBIT
X4 [11]	H	L	L	VCR1	VCR1
X5 [6]	H	L	H	VCR2/DVR	VCR2/DVR
X6 [2]	H	H	L	CABLE	CABLE
X7 [4]	H	H	H	V-AUX	V-AUX

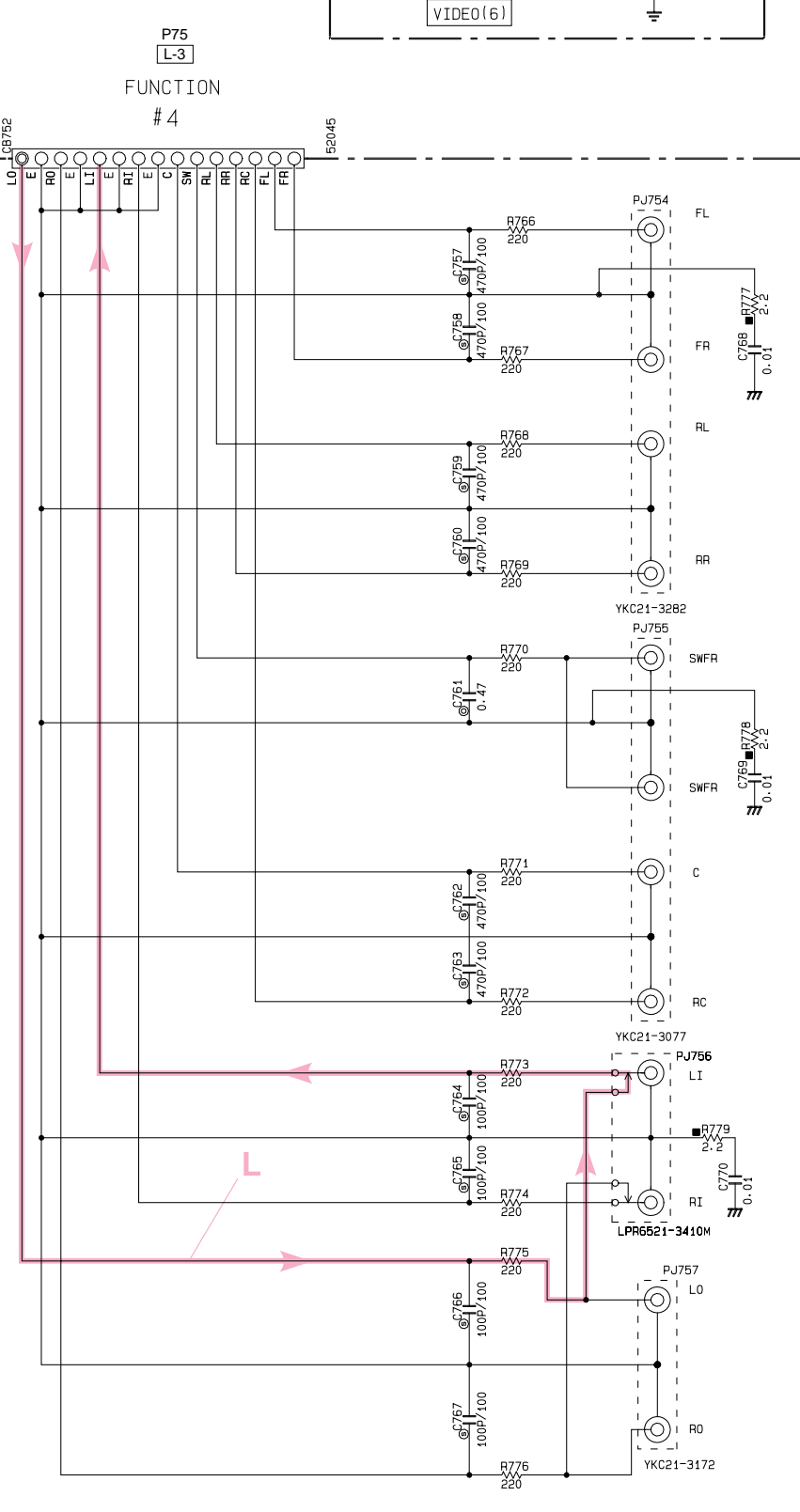
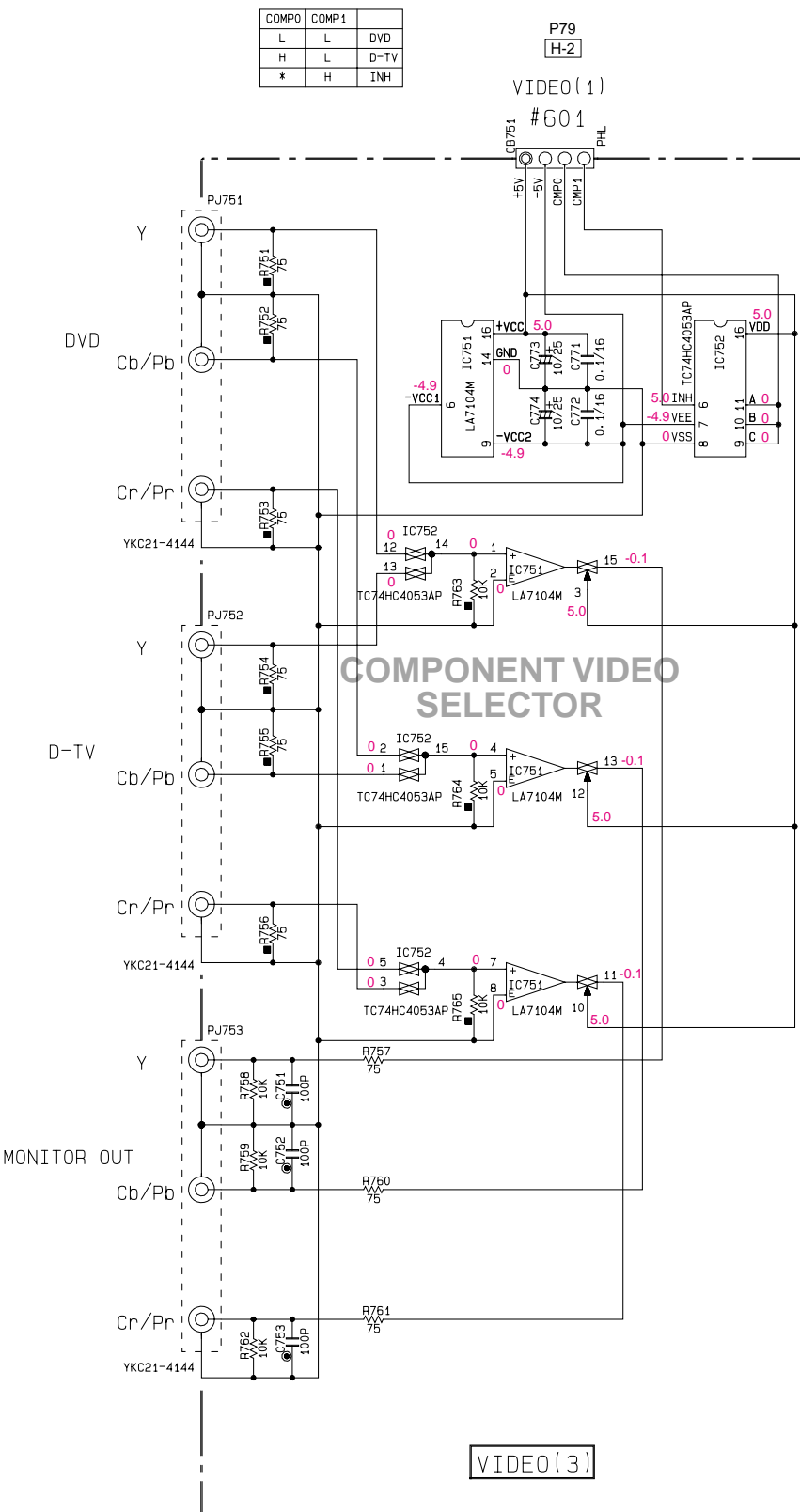
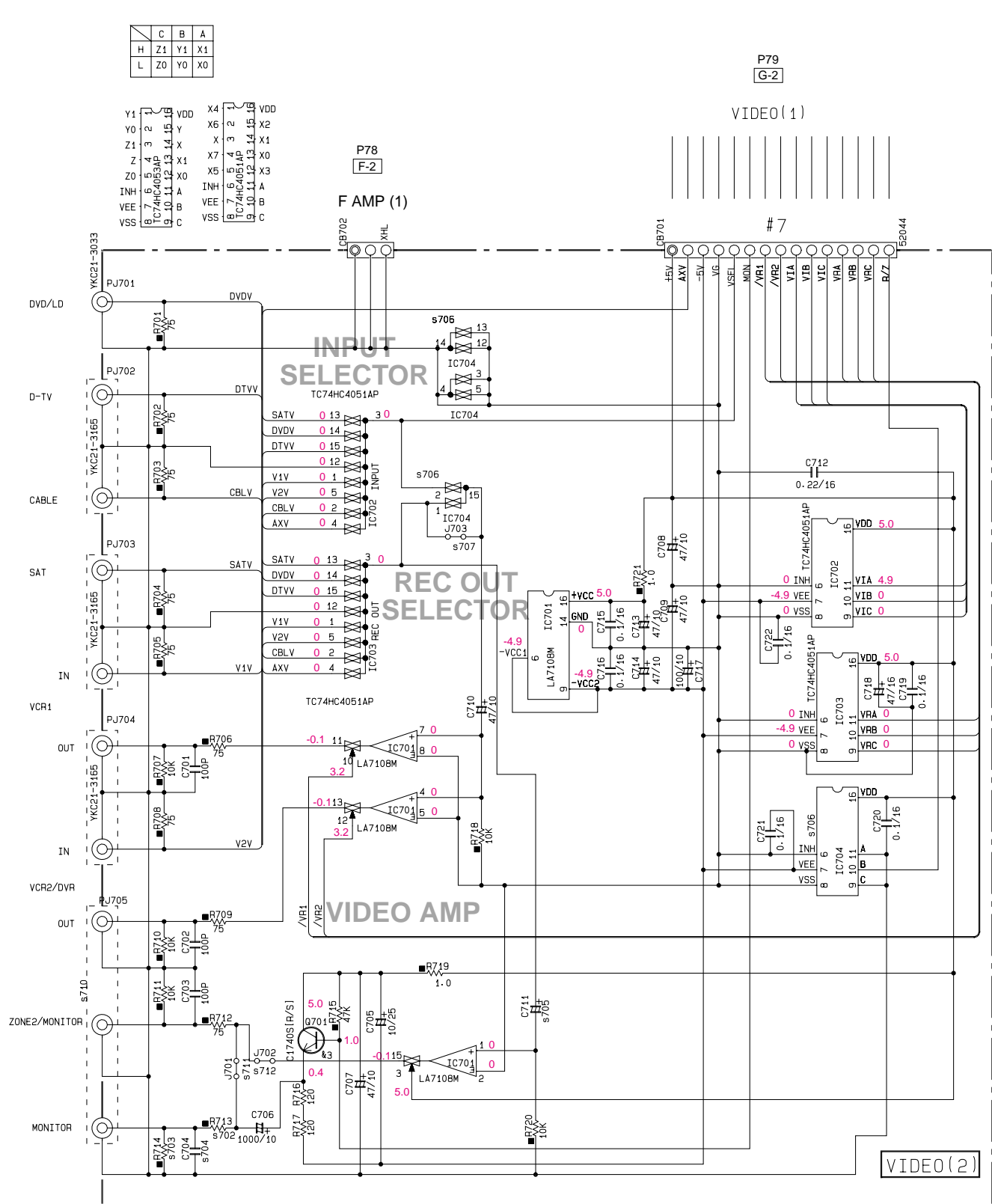
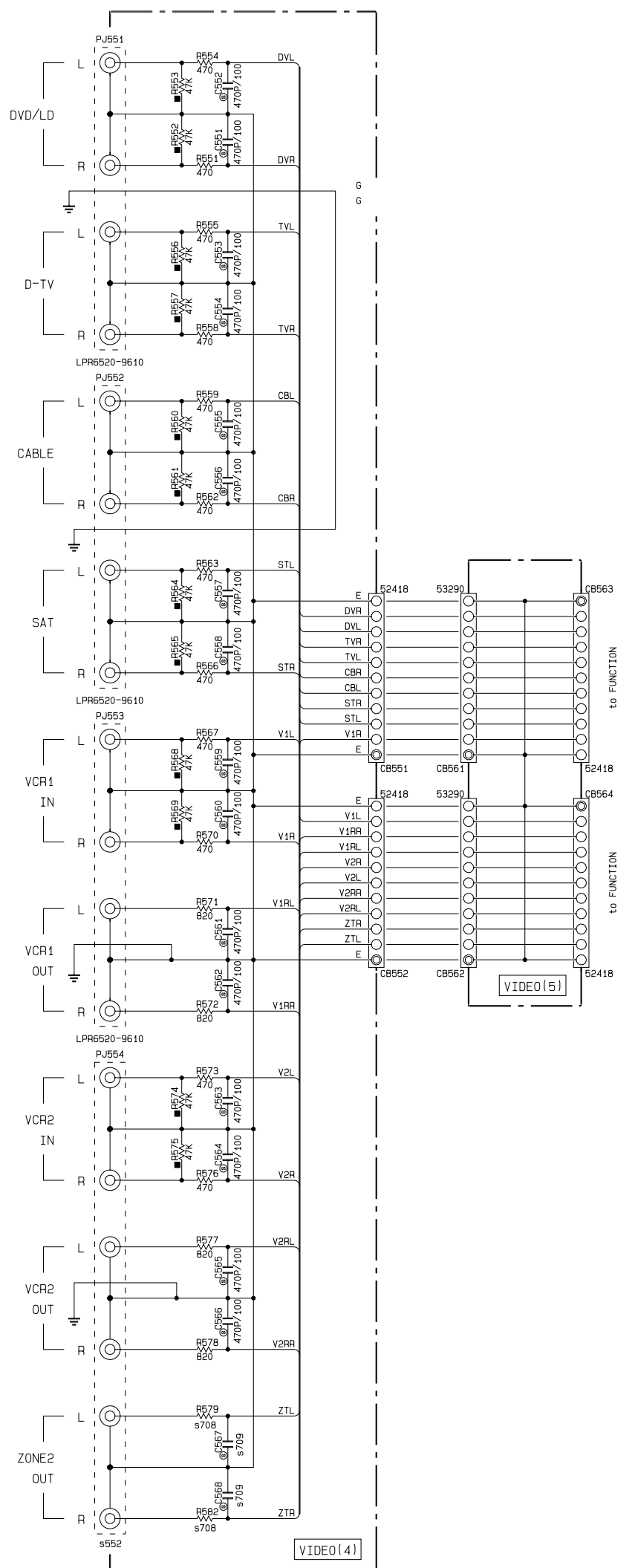
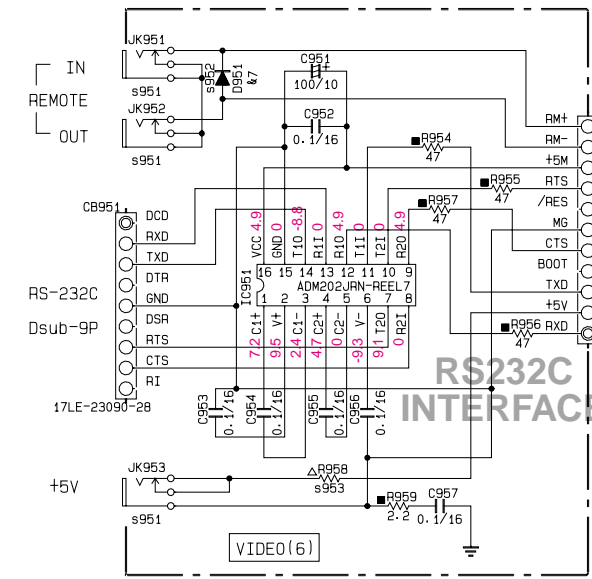

IC702, 703 : TC74HC4051AP Analog Multiplexer/Demultiplexer

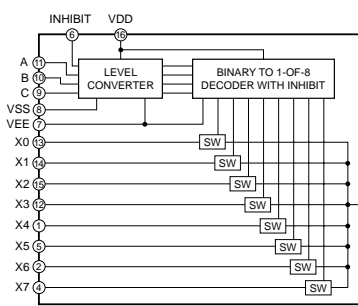

INPUT STATES	'ON' CHANNEL (S)
INHIBIT C B A	
0 0 0 0	1
0 0 0 1	2
0 0 1 0	3
0 0 1 1	4
0 1 0 0	5
0 1 0 1	6
0 1 1 0	7
0 1 1 1	8
1 X X X	NONE

IC704, 752 : TC74HC4053AP Triple 2-Channel Multiplexer/Demultiplexer

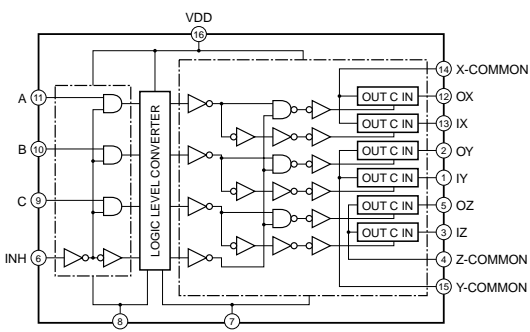

CONTROL INPUTS	'ON' CHANNEL
INHIBIT C B A	0X (Pin 12), 0Y (Pin 2), 0Z (Pin 5)
0 0 0 0	0X, 0Y, 0Z
0 0 0 1	0X, 0Y, 0Z
0 0 1 0	0X, 0Y, 0Z
0 0 1 1	0X, 0Y, 0Z
0 1 0 0	0X, 0Y, 0Z
0 1 0 1	0X, 0Y, 0Z
0 1 1 0	0X, 0Y, 0Z
0 1 1 1	0X, 0Y, 0Z
1 X X X	NOTE

IC701 : LA7108M-TLM 75Ω Video Driver

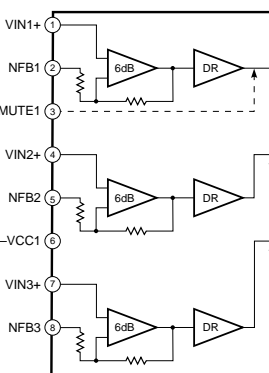

IC751 : LA7104M Double Scart Interface

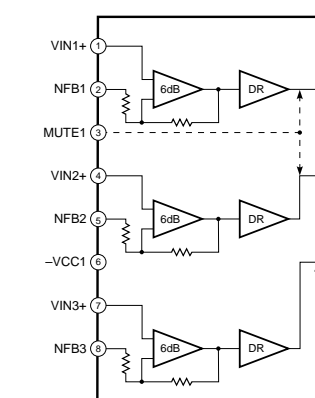

IC951 : HIN202ECBN-T RS-232 Line Drive/Receiver

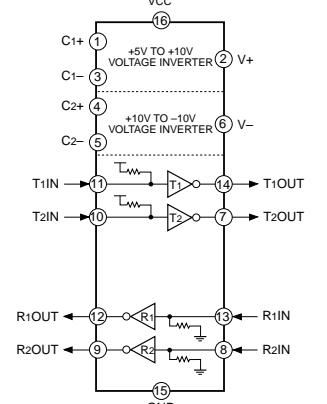

Conditions

- INPUT: DVD auto
- PROGRAM: PRO LOGIC DSP

* All voltage are measured with a 10MΩ/V DC electric volt meter.
 * Components having special characteristics are marked △ and must be replaced with parts having specifications equal to those originally installed.
 * Schematic diagram is subject to change without notice.